



Finished Size: **52" x 65" (1.32m x 1.65m)**

Finished Block Size: **12" x 12"**

Fabric Collection Name and Fabric Designer: **My Darling Unicorn by Karissa Schulten**

Technique: **Pieced**

Designed by: **Henry Glass & Co.**

Skill Level: **Advanced Beginner**

Tech Edited by: **Emma Lea Creative**

# Dancing Squares Quilt

## Fabric Requirements

| DESIGN                       | COLOR    | ITEM ID   | YARDAGE          |
|------------------------------|----------|-----------|------------------|
| (A) Rainbows and Unicorns    | Pink     | 2274-02   | 1¼ yards (1.14m) |
| (B) Tossed Unicorns          | Pink     | 2275-22   | 1⅛ yards (1.03m) |
| (C) Small Wallpaper Stripe   | Multi    | 2278-52*  | ⅝ yard (0.57m)   |
| (D) Unicorns in Forest Scene | Lavender | 2279-50   | 1⅜ yards (1.26m) |
| (E) Stars                    | Pink     | 2280-22   | ⅝ yard (0.57m)   |
| (F) Stars                    | Purple   | 2280-55   | 1 yard (0.91m)   |
| (G) Book Panel               | Multi    | 2281BP-52 | 1 yard (0.91m)   |

\* includes binding



(A)



(B)



(C)



(D)

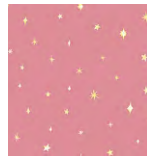

(E)



(F)



(G)

## Backing (Purchased Separately)

44" (1.12m) wide

Shooting Stars and Clouds

Lavender

2273-50

3½ yards (3.20m)

OR

108" (2.74m) wide

1¾ yards (1.60m)



Backing  
44"

## Additional Materials:

- 12½" square acrylic ruler or template plastic
- 100% Cotton Thread
- Batting: 60" x 73" (1.52m x 1.85m)

*All possible care has been taken to ensure the accuracy of this pattern. We are not responsible for printing errors or the manner in which individual work varies.*

*Please read the instructions carefully before starting this project. If kitting it is recommended a sample is made to confirm accuracy.*

*All free projects are intended to remain free and are not for resale.*

## CUTTING

### Notes:

- Please make sure to check [www.henryglassfabrics.net](http://www.henryglassfabrics.net) for pattern updates prior to starting the project.
- All strips are cut across the width of fabric (WOF) from selvedge to selvedge edge unless otherwise noted.

### Fabric A, cut:

- (6) 3½" x WOF; subcut
  - (12) 3½" x 16½" rectangles
- (2) 10½" x WOF; subcut
  - (12) 10½" x 3½" rectangles

### Fabric B, cut:

- (6) 3½" x WOF; subcut
  - (12) 3½" x 16½" rectangles
- (4) 3½" x WOF; subcut
  - (12) 3½" x 10½" rectangles

### Fabric C, cut:

- (7) 2½" x WOF for the binding

### Fabric D, cut:

- (7) 6½" x WOF for border 2

### Fabric E, cut:

- (11) 1½" x WOF
  - From (3) strips; subcut
    - (8) 1½" x 12½" rectangles
  - Set aside (3) strips for the horizontal sashing and (5) for border 1

### Fabric F, cut:

- (2) 12" x WOF; subcut
  - (24) 2½" x 12" rectangles
  - (8) 2½" x 8½" rectangles
- (1) 8½" x WOF; subcut
  - (16) 2½" x 8½" rectangles

### Fabric G, fussy cut:

- (12) 8¼" squares\*\*\*

\*\*\*Cut out the book panel block approximately ⅛" outside the edge of the page, ensuring you cut a square. There should be approximately ⅛" white outside edge on your trimmed blocks, but not more than ¼" on any side. This size will not be exact, but will be trimmed to fit in step 1.

## SEWING

**Notes:** All seam allowances are  $\frac{1}{4}$ " (0.64cm). Sew pieces with right sides together. Press seam allowances open unless otherwise indicated.

1. Sew (2)  $2\frac{1}{2}$ " x  $8\frac{1}{2}$ " **Fabric F** rectangles to opposite sides of (1) **Fabric G** square. Press the seams away from the center. Trim ends of **Fabric G** even with sides of **Fabric F** (**Fig. 1**). Sew (1)  $2\frac{1}{2}$ " x 12" **Fabric F** rectangle to the top and bottom of the **Fabric G** square, centering the **Fabric F** rectangle. Press as before. Trim the block to  $10\frac{1}{2}$ ", centering the panel artwork. Repeat to make (12) block centers total (**Fig. 2**).

**Fig. 1**

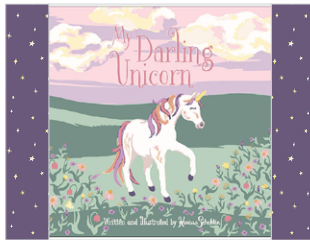

**Fig. 2**



2. Using the cover image (page 1) or your preference, select (6) blocks to lean left. Sew (2)  $3\frac{1}{2}$ " x  $10\frac{1}{2}$ " **Fabric A** rectangles to opposite sides of a block center. Press. Sew (1)  $3\frac{1}{2}$ " x  $16\frac{1}{2}$ " **Fabric A** rectangle to the top and bottom of the block center. Press. Repeat to make (6) **Fabric A** blocks total (**Fig. 3**).

**Fig. 3**



*All possible care has been taken to ensure the accuracy of this pattern. We are not responsible for printing errors or the manner in which individual work varies.*

*Please read the instructions carefully before starting this project. If kitting it is recommended a sample is made to confirm accuracy.*

*All free projects are intended to remain free and are not for resale.*

- Repeat step 2 with the  $3\frac{1}{2}$ " x  $10\frac{1}{2}$ " and  $3\frac{1}{2}$ " x  $16\frac{1}{2}$ " **Fabric B** rectangles, and the remaining block centers to make (6) **Fabric B** blocks total (**Fig. 4**).

**Fig. 4**



- Gather a **Fabric A** block. Place a  $12\frac{1}{2}$ " square acrylic ruler\* on the block at an angle using the dashed lines in **Fig. 5** as a guide. Ensure all four corners of the template or ruler intersect with block boundaries about the same amount. Trim around all four sides of the template or ruler to complete the block. Repeat to make (6)  $12\frac{1}{2}$ " left-leaning blocks total (**Fig. 6**).

**Fig. 5**

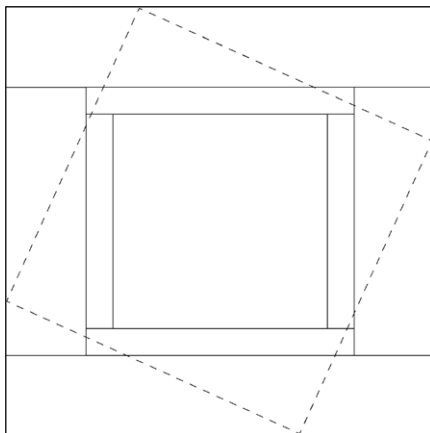

**Fig. 6**



\*Alternatively, cut the plastic template into a  $12\frac{1}{2}$ " square. Use this template as you would the  $12\frac{1}{2}$ " square acrylic ruler. For safety, after you are satisfied with the placement of the square template, align an acrylic ruler with the edge of the template before cutting with the rotary cutter.

*All possible care has been taken to ensure the accuracy of this pattern. We are not responsible for printing errors or the manner in which individual work varies.*

*Please read the instructions carefully before starting this project. If kitting it is recommended a sample is made to confirm accuracy.*

*All free projects are intended to remain free and are not for resale.*

5. Gather a **Fabric B** block. Place a 12½" square acrylic ruler or template on the block at an angle using the dashed lines in **Fig. 7** as a guide. Ensure all four corners of the template or ruler intersect with block boundaries about the same amount. Trim around all four sides of the template or ruler to complete the block. Repeat to make (6) 12½" right-leaning blocks total (**Fig. 8**).

**Fig. 7**

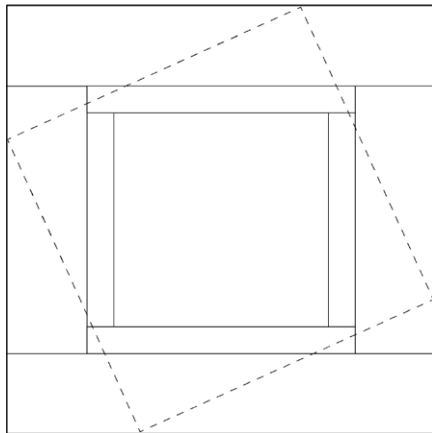

**Fig. 8**



## QUILT ASSEMBLY

**Note:** Follow the quilt Layout Diagram (page 7) while assembling the top.

6. Referring to the quilt photo for block placement, lay out (4) rows with (3) blocks and (2) 1½" x 12½" **Fabric E** sashing rectangles each. Sew the blocks and sashing together in each row. Press the seams toward the sashing.
7. To make the horizontal sashing rows, measure the length of a few block rows to determine the average length. Trim (3) 1½" **Fabric E** strips to that length (approx. 38½"). Sew the block and horizontal sashing rows together. Press the seams in one direction.
8. For border 1, sew the (5) 1½" **Fabric E** strips together end to end using diagonal seams. Measure the vertical length of the quilt top through the center and cut (2) border strips to that length (approx. 51½"). Sew (1) strip to each side of the quilt top and press the seams toward the borders. Measure the width of the quilt top through the center. Cut (2) border strips to that length (approx. 40½") and sew (1) to the top and bottom. Press the seams toward the borders.
9. Repeat step 8 with the (7) 6½" **Fabric D** strips to make and add border 2. Cut strips to approx. 53½" and 52½", respectively.

*All possible care has been taken to ensure the accuracy of this pattern. We are not responsible for printing errors or the manner in which individual work varies.*

*Please read the instructions carefully before starting this project. If kitting it is recommended a sample is made to confirm accuracy.*

*All free projects are intended to remain free and are not for resale.*

## FINISHING

10. Sew together the (7) 2½" **Fabric C** binding strips end to end using diagonal seams. Press the seams open. Press the binding strip in half with the wrong sides together.
11. Layer the backing (wrong side up), batting, and quilt top (right side up). Baste the layers together and quilt as desired. Trim excess batting and backing even with the top of the quilt.
12. Leaving an 8" tail of binding and beginning along an edge of the quilt, matching the raw edges of the binding to the raw edges of the quilt. Sew the binding to the outside edge around all four sides and miter corners. Stop sewing approximately 12" from where you started and backstitch.
13. Lay both loose ends of the binding flat along the quilt's edge. Where these two loose ends meet, fold them back onto themselves and press to form a crease. Using this crease as your stitching line, sew the two open ends of the binding together, with the right sides matching. Trim the seam to ¼" and press it open. Finish sewing the binding to the quilt.
14. Turn the binding over the raw edge to the back of the quilt and hand or machine stitch in place.

## Quilt Layout

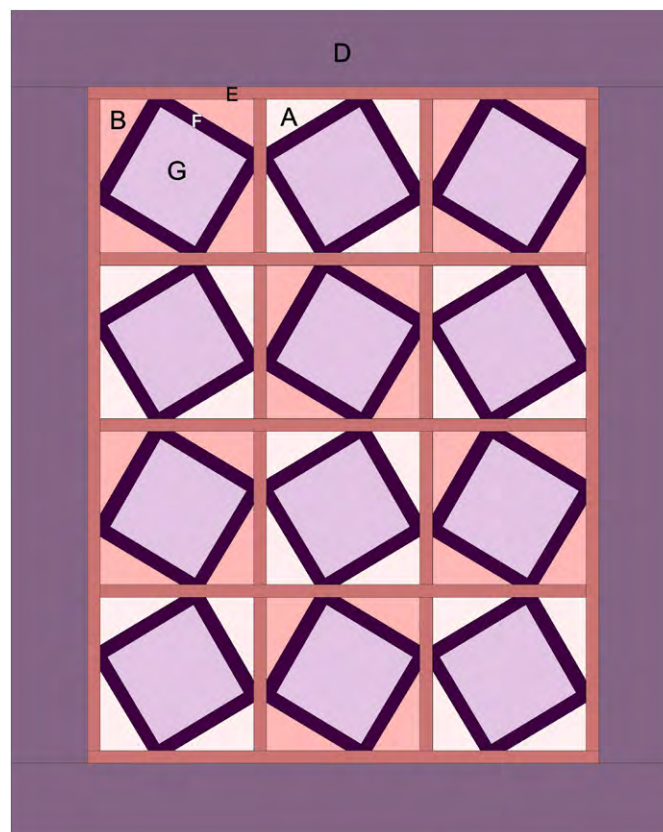

*All possible care has been taken to ensure the accuracy of this pattern. We are not responsible for printing errors or the manner in which individual work varies.*

*Please read the instructions carefully before starting this project. If kitting it is recommended a sample is made to confirm accuracy.*

*All free projects are intended to remain free and are not for resale.*