



Finished Size: **52" x 65" (1.32m x 1.65m)**

Finished Block Size: **12" x 12"**

Fabric Collection Name and Fabric Designer: **Milky Way by Kate Mawdsley**

Technique: **Pieced**

Designed by: **Henry Glass & Co.**

Skill Level: **Advanced Beginner**

Tech Edited by: **Emma Lea Creative**

Fabric Requirements

DESIGN	COLOR	ITEM ID	YARDAGE
(A) Galaxy	Gray	2114G-90	1 $\frac{1}{8}$ yards (1.03m)
(B) Starry	Navy	2115G-78	$\frac{5}{8}$ yard (0.57m)
(C) Shooting Stars	Navy	2117G-78*	$\frac{5}{8}$ yard (0.57m)
(D) Astronauts	Gray	2118G-90	1 $\frac{3}{8}$ yards (1.26m)
(E) Tossed Elements	Teal	2119G-76	1 $\frac{1}{8}$ yards (1.03m)
(F) Book Panel	Navy	2121BPG-78	1 yard (0.91m)
(G) Starry Basics	Orange	8294-35	1 yard (0.91m)

* includes binding



(A)

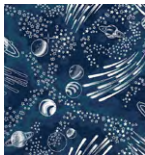

(B)



(C)

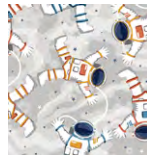

(D)



(E)



(F)



(G)

Backing (Purchased Separately)

44" (1.12m) wide

Tossed Rockets

Navy

2113G-78

3 $\frac{1}{2}$ yards (3.20m)

OR

108" (2.74m) wide

1 $\frac{3}{4}$ yards (1.60m)



Backing
44"

Additional Materials:

- 12 $\frac{1}{2}$ " square acrylic ruler or plastic for template
- 100% Cotton Thread
- Batting: 60" x 73" (1.52m x 1.85m)

All possible care has been taken to ensure the accuracy of this pattern. We are not responsible for printing errors or the manner in which individual work varies.

Please read the instructions carefully before starting this project. If kitting it is recommended a sample is made to confirm accuracy.

All free projects are intended to remain free and are not for resale.

CUTTING

Notes:

- Please make sure to check henryglassfabrics.net for pattern updates prior to starting the project.
- All strips are cut across the width of fabric (WOF) from selvedge to selvedge edge unless otherwise noted.

Fabrics A and E, from each cut:

- (6) 3½" x WOF; subcut
 - (12) 3½" x 16½" rectangles
- (4) 3½" x WOF; subcut
 - (12) 3½" x 10½" rectangles

Fabric B, cut:

- (11) 1½" x WOF
 - From (3) strips; subcut
 - (8) 1½" x 12½" rectangles
 - Set aside (3) strips for the horizontal sashing and (5) for border 1

Fabric C, cut:

- (7) 2½" x WOF for the binding

Fabric D, cut:

- (7) 6½" x WOF for border 2

Fabric F, fussy cut:

- (12) 7⅝" squares***

Fabric G, cut:

- (2) 12" x WOF; subcut
 - (24) 2½" x 12" rectangles
 - (8) 2½" x 8" rectangles
- (1) 8" x WOF; subcut
 - (16) 2½" x 8" rectangles

***Cut out the book panel block through the approximate middle of the first white border closest to each page, ensuring you cut a square. There should be some white remaining on your trimmed blocks, but not more than ¼" on each side. This size will not be exact, but will be trimmed to fit in step 1.

SEWING

Note: All seam allowances are $\frac{1}{4}$ " (0.64cm). Sew pieces with right sides together.

1. Sew (2) $2\frac{1}{2}$ " x 8" **Fabric G** rectangles to opposite sides of (1) **Fabric F** square. Press the seams away from the center. Trim ends of **Fabric G** even with sides of **Fabric F**. Sew (1) $2\frac{1}{2}$ " x 12" **Fabric G** rectangle to the top and bottom of the **Fabric F** square. Press seams away from the center. Trim the block to $10\frac{1}{2}$ ", centering the panel artwork. Repeat to make (12) $10\frac{1}{2}$ " block centers total (**Fig. 1**).

Fig. 1

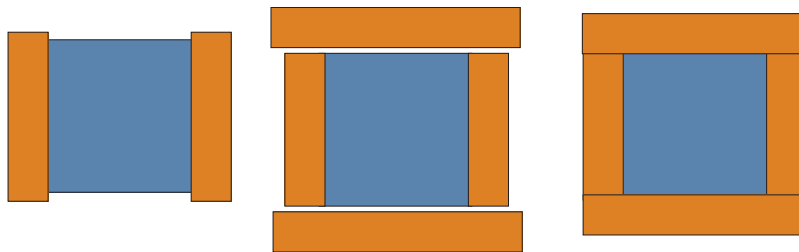

2. Using the cover image, or your preference, select (6) block centers to lean left. Sew (2) $3\frac{1}{2}$ " x $10\frac{1}{2}$ " **Fabric A** rectangles to opposite sides of the block center. Press seams open. Sew (2) $3\frac{1}{2}$ " x $16\frac{1}{2}$ " **Fabric A** rectangles to the top and bottom of the block center. Press seams open. Repeat to make (6) **Fabric A** blocks total (**Fig. 2**).

Fig. 2

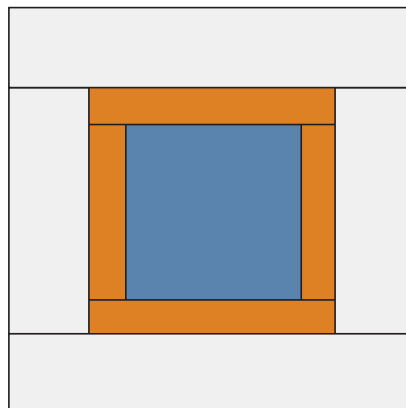

All possible care has been taken to ensure the accuracy of this pattern. We are not responsible for printing errors or the manner in which individual work varies.

Please read the instructions carefully before starting this project. If kitting it is recommended a sample is made to confirm accuracy.

All free projects are intended to remain free and are not for resale.

- Repeat step 2 with the $3\frac{1}{2}$ " x $10\frac{1}{2}$ " and $3\frac{1}{2}$ " x $16\frac{1}{2}$ " **Fabric E** rectangles, and the remaining block centers to make (6) **Fabric E** blocks total (**Fig. 3**).

Fig. 3

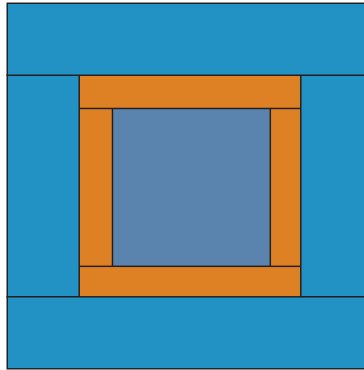

- Gather a step 2 **Fabric A** block. Place a $12\frac{1}{2}$ " square acrylic ruler* in the center, then rotate the ruler to a slight angle using the dashed lines in **Fig. 4** as examples. All four corners of the template or ruler should touch or overlap the borders about the same amount. Trim around all four sides of the ruler or template to complete the block. Repeat to make (6) $12\frac{1}{2}$ " left-leaning blocks (**Fig. 4**).

Fig. 4

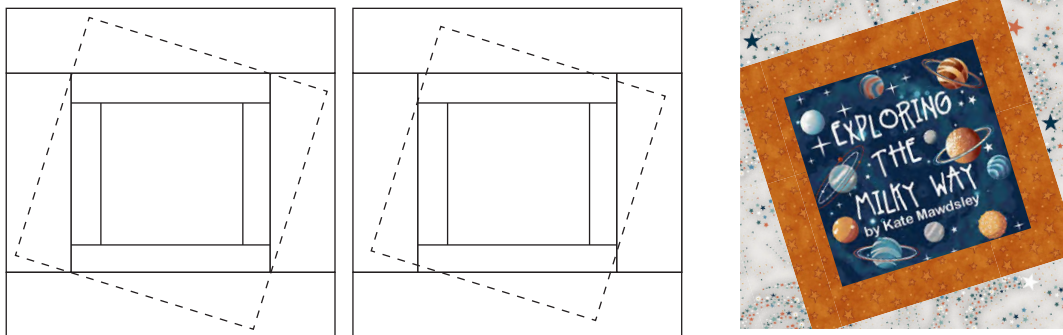

*Alternatively, cut the plastic template into a $12\frac{1}{2}$ " square. Use this template as you would the $12\frac{1}{2}$ " square acrylic ruler. For safety, after you are satisfied with the placement of the square template, align an acrylic ruler with the edge of the template before cutting with the rotary cutter.

All possible care has been taken to ensure the accuracy of this pattern. We are not responsible for printing errors or the manner in which individual work varies.

Please read the instructions carefully before starting this project. If kitting it is recommended a sample is made to confirm accuracy.

All free projects are intended to remain free and are not for resale.

5. Gather a step 3 **Fabric E** block. Place a 12½" square acrylic ruler (see note on page 5) on the block at an angle using the dashed lines in **Fig. 5** as examples. All four corners of the template or ruler should touch or overlap the borders about the same amount. Trim around all four sides of the ruler or template to complete the block. Repeat to make (6) 12½" right-leaning blocks (**Fig. 5**).

Fig. 5

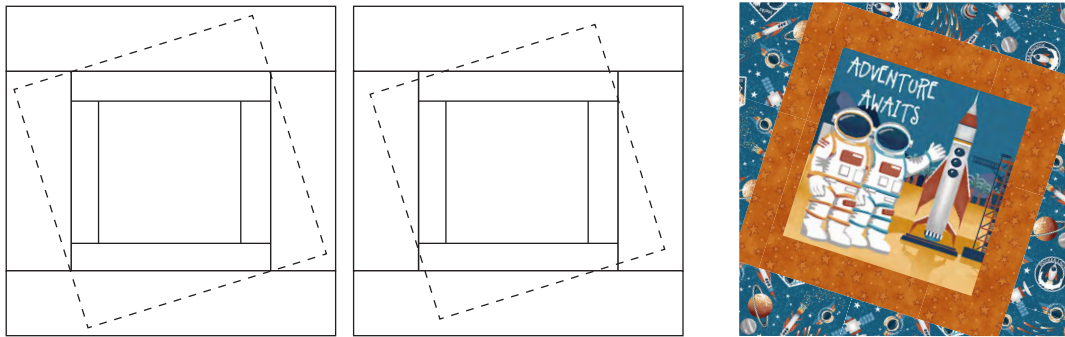

QUILT ASSEMBLY

Note: Follow the Quilt Layout on page 7 while assembling the top.

6. Referring to the quilt image for block placement, lay out (4) rows with (3) blocks and (2) 1½" x 12½" **Fabric B** sashing rectangles each. Sew the blocks and sashing together in each row. Press the seams toward the sashing.
7. To make the horizontal sashing rows, measure the length of a few block rows to determine the average length (should equal approximately 38½"). Trim (3) 1½" **Fabric B** strips to that length. Sew the block and horizontal sashing rows together. Press the seams in one direction.
8. For border 1, sew the (5) 1½" **Fabric B** strips together end to end using diagonal seams. Measure the vertical length of the quilt top through the center and cut (2) border strips to that length. Sew (1) strip to each side of the quilt top and press the seams toward the borders. Measure the width of the quilt top through the center. Cut (2) border strips to that length and sew to the top and bottom of the quilt top. Press the seams toward the borders.
9. Repeat step 8 with the (7) 6½" **Fabric D** strips to make and add border 2.

All possible care has been taken to ensure the accuracy of this pattern. We are not responsible for printing errors or the manner in which individual work varies.

Please read the instructions carefully before starting this project. If kitting it is recommended a sample is made to confirm accuracy.

All free projects are intended to remain free and are not for resale.

Quilt Layout

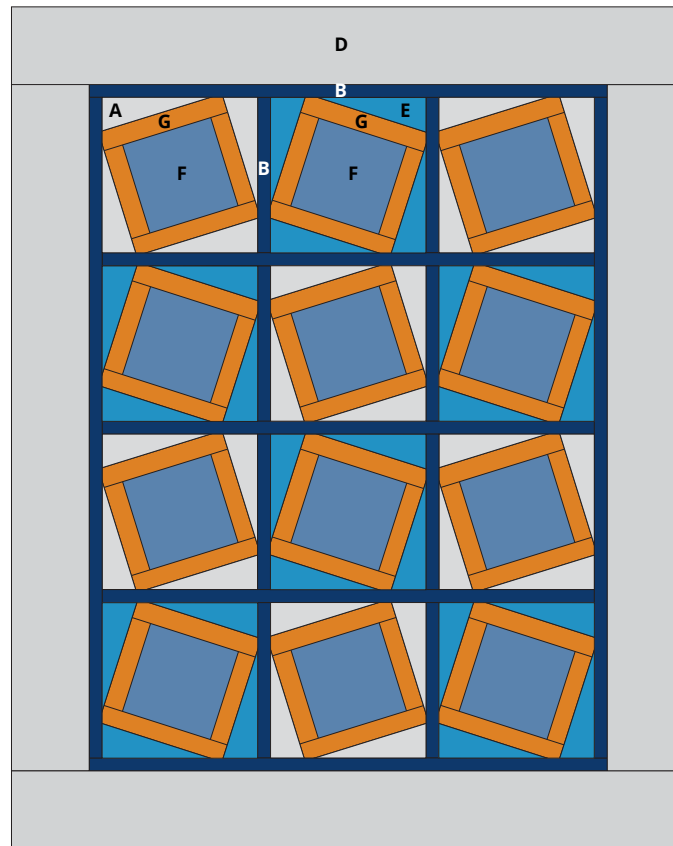

FINISHING

10. Sew together the (7) 2½" **Fabric C** binding strips end to end using diagonal seams. Press the seams open. Press the binding strip in half with the wrong sides together.
11. Layer the backing (wrong side up), batting, and quilt top (right side up). Baste the layers together and quilt as desired. Trim excess batting and backing even with the top of the quilt.
12. Leaving an 8" tail of binding and beginning along an edge of the quilt, match the raw edges of the binding to the raw edges of the quilt. Sew the binding to the outside edge around all four sides and miter corners. Stop sewing approximately 12" from where you started and backstitch.
13. Lay both loose ends of the binding flat along the quilt's edge. Where these two loose ends meet, fold them back onto themselves and press to form a crease. Using this crease as your stitching line, sew the two open ends of the binding together, with the right sides matching. Trim the seam to ¼" and press it open. Finish sewing the binding to the quilt.
14. Turn the binding over the raw edge to the back of the quilt and hand or machine stitch in place.

All possible care has been taken to ensure the accuracy of this pattern. We are not responsible for printing errors or the manner in which individual work varies.

Please read the instructions carefully before starting this project. If kitting it is recommended a sample is made to confirm accuracy.

All free projects are intended to remain free and are not for resale.